

TOTAL LENGTH CLOSE: 2550mm  
 TOTAL LENGTH OPEN: 5050mm  
 HARM CLOSED: 2200mm  
 HARM OPEN: 4700mm  
**RUN: 2500mm**

OIL TANK

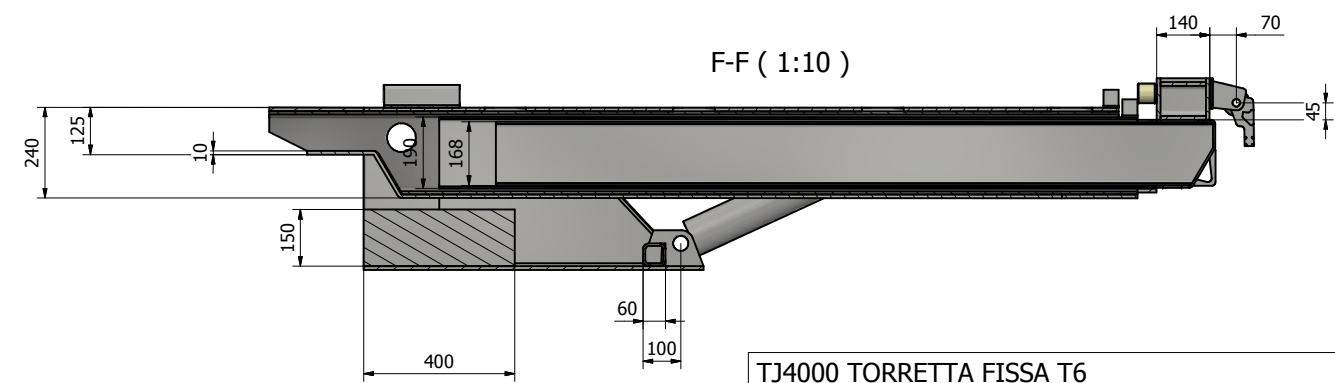
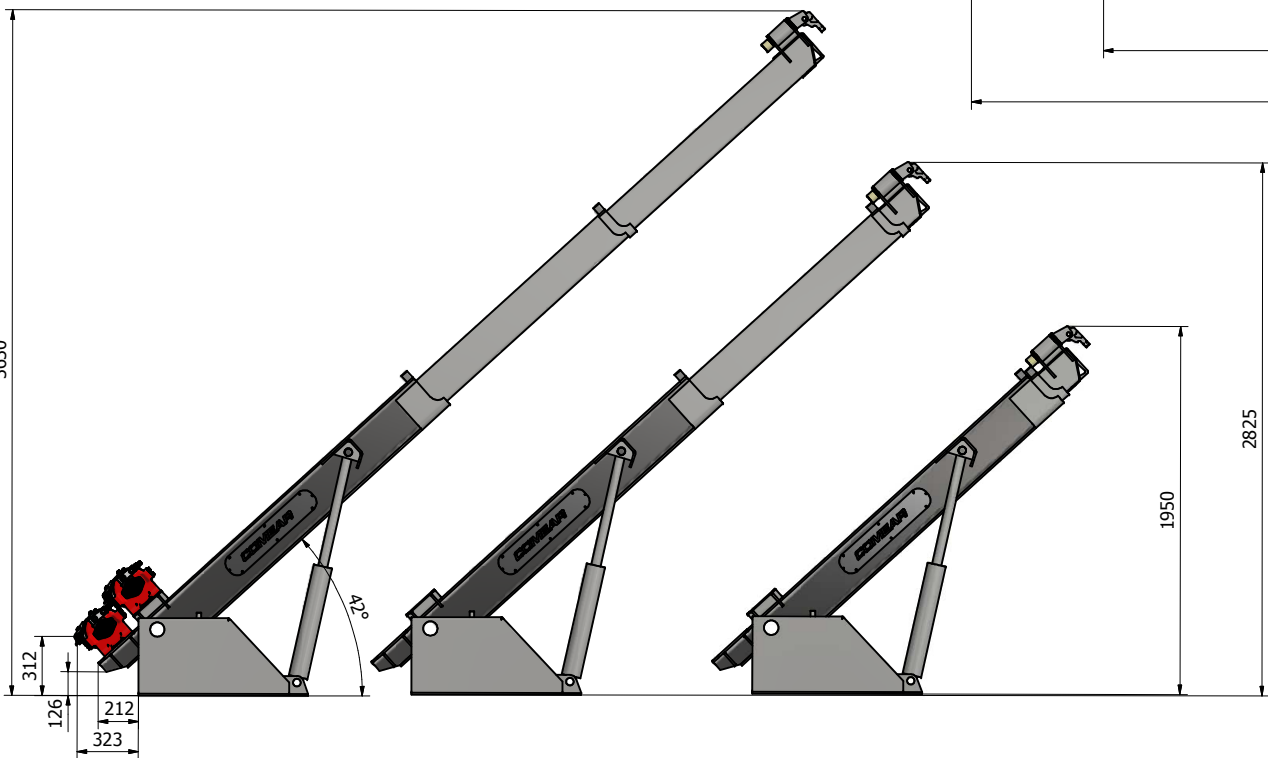

TJ4000 TORRETTA FISSA T6			
DIS.	SCALA 1:10	FOGLIO 1 / 1	
MATERIALE	DATA STAMPA:	ARROTONDARE TUTTI GLI SPIGOLI	RUGGOSITÀ Ra in $\mu$
DESEGNAO M. Molinari	DATA: 20/03/2019	R = 0.4 -1 mm	✓
QUOTE SENZA INDICAZIONE DI TOLLERANZA Grado di precisione medio UNI 5307 SIMBOLI DI SALDATURA SECONDO UNI 1310-86 Saldature: a=0.7 dello spessore minimo da collegare 			
Via Grazia Deledda N.39 Località Fascia d'Oro 25018 MONTICHIARI BRESCIA			
<small>N. B. A termini di legge ci riserviamo la proprietà di questo disegno con divieto di riproduzione.</small>			